

Armatura temeljnih traka - Rubna armatura  
mj 1:50, C25/30, cnom=4,0 cm

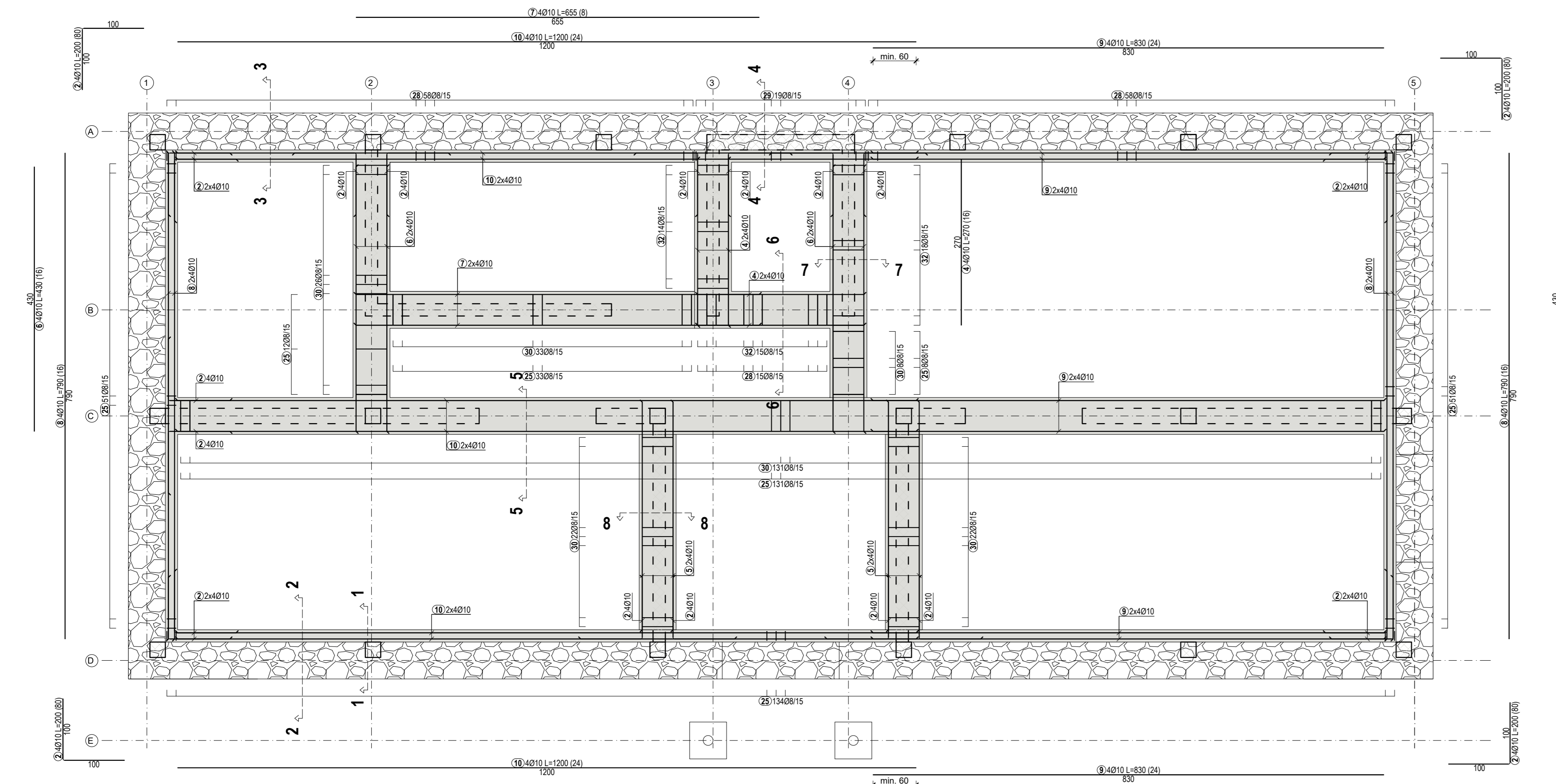

Armatura temeljnih traka - Donja i gornja zona  
mj 1:50, C25/30, cnom=4,0 cm

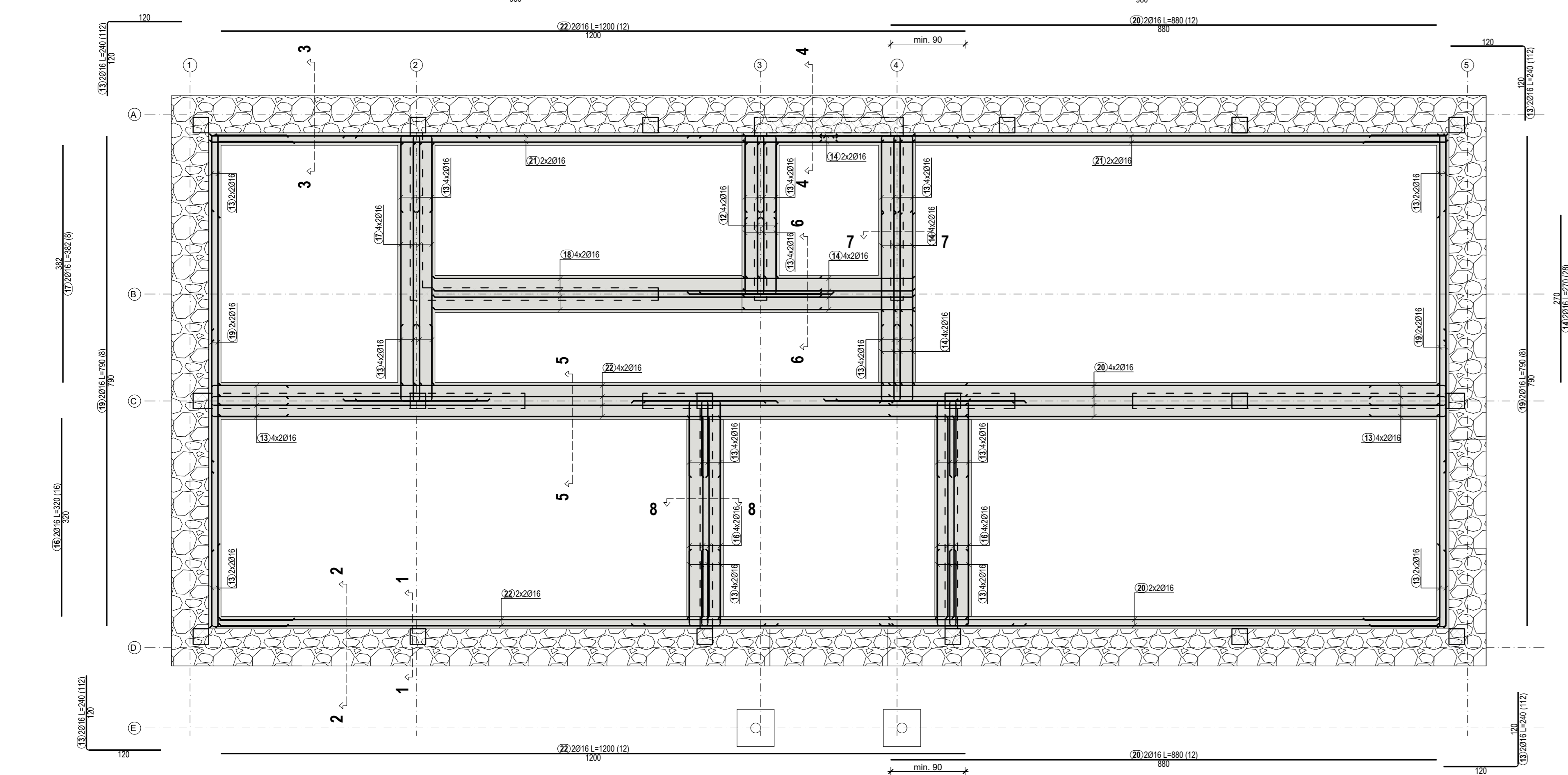

Armatura temeljnih traka - Podna ploča  
mj 1:50, C25/30, cnom=4,0 cm

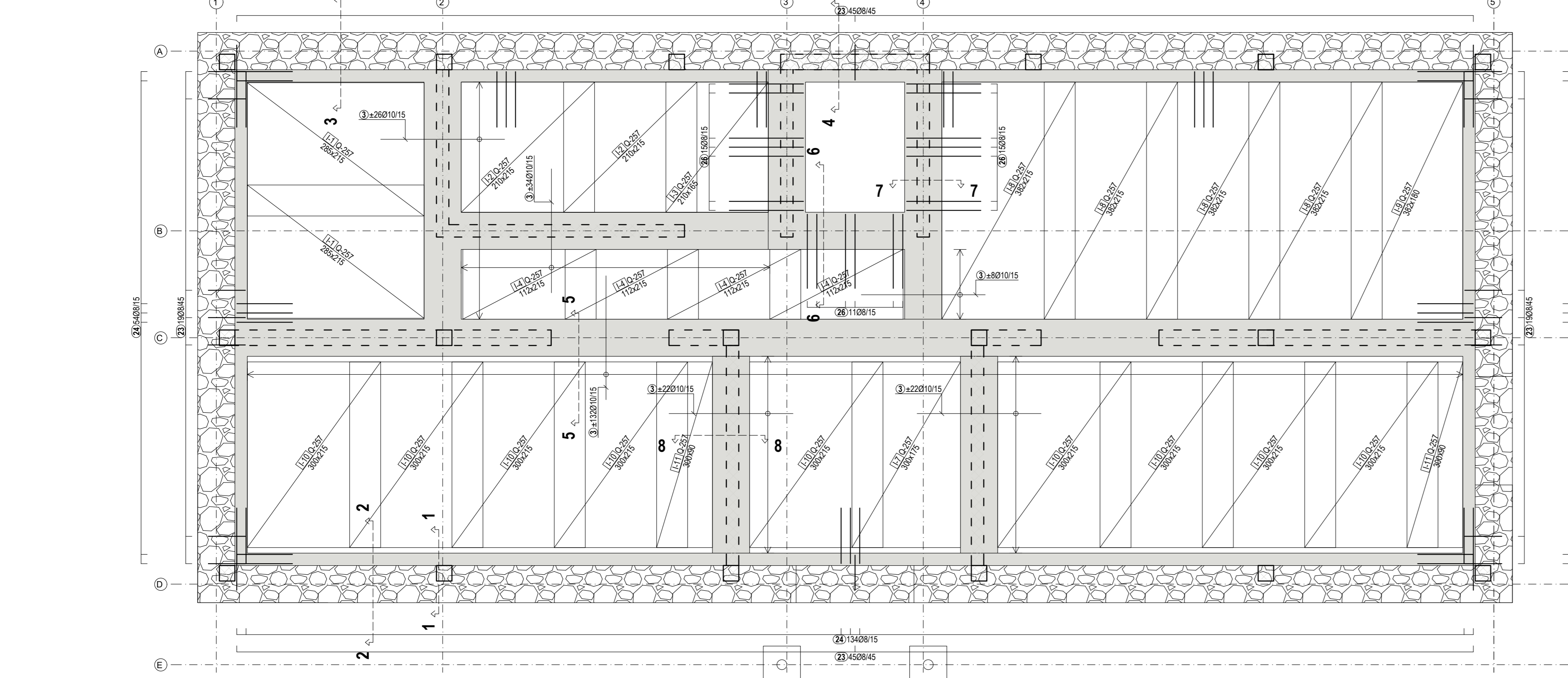

Armatura temeljnih traka - Podna ploča lifta i ankeri  
mj 1:50, C25/30, cnom=4,0 cm

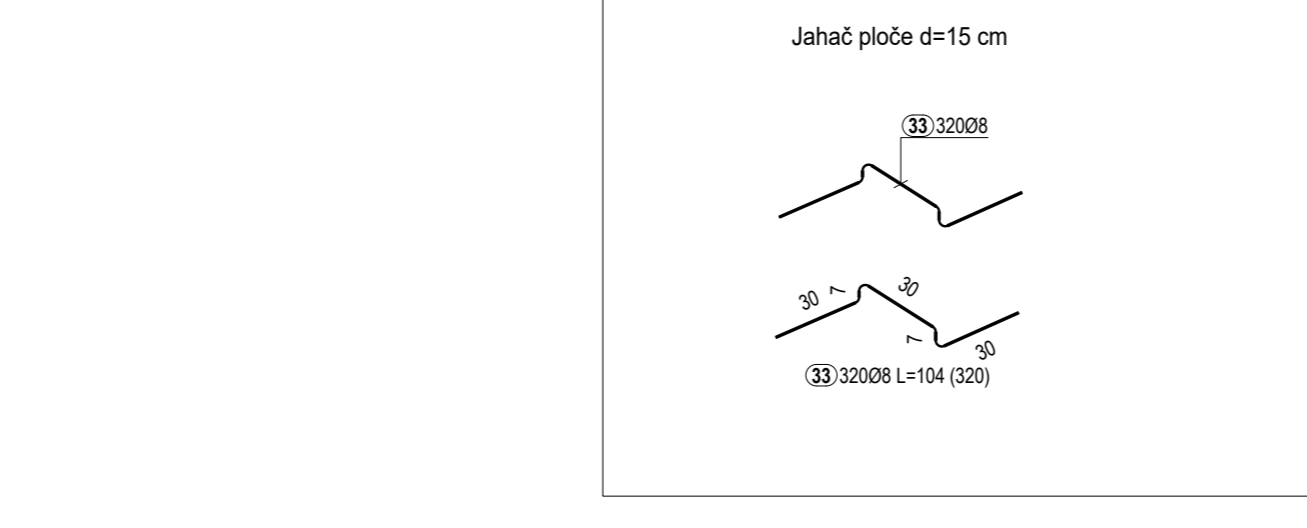
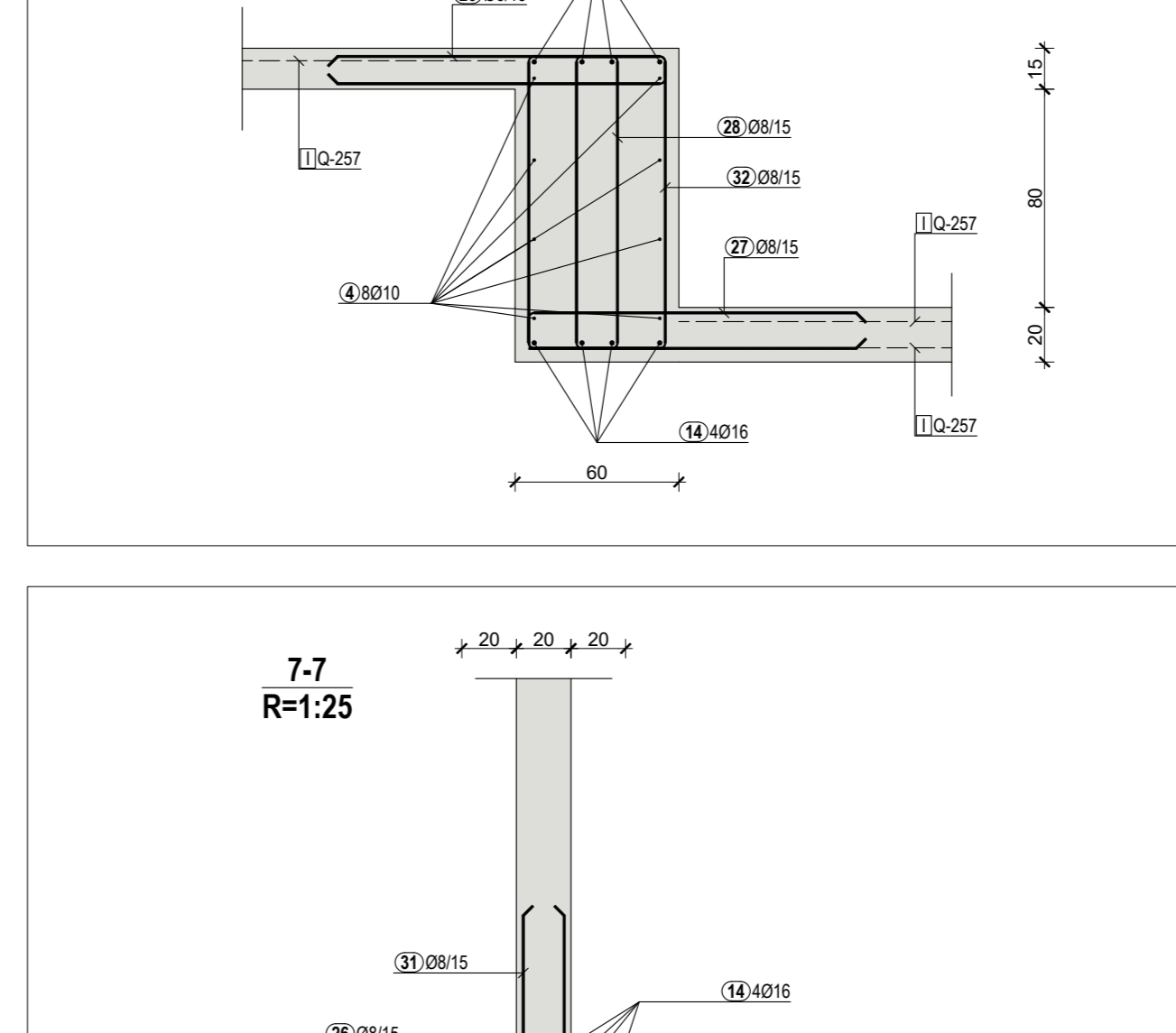
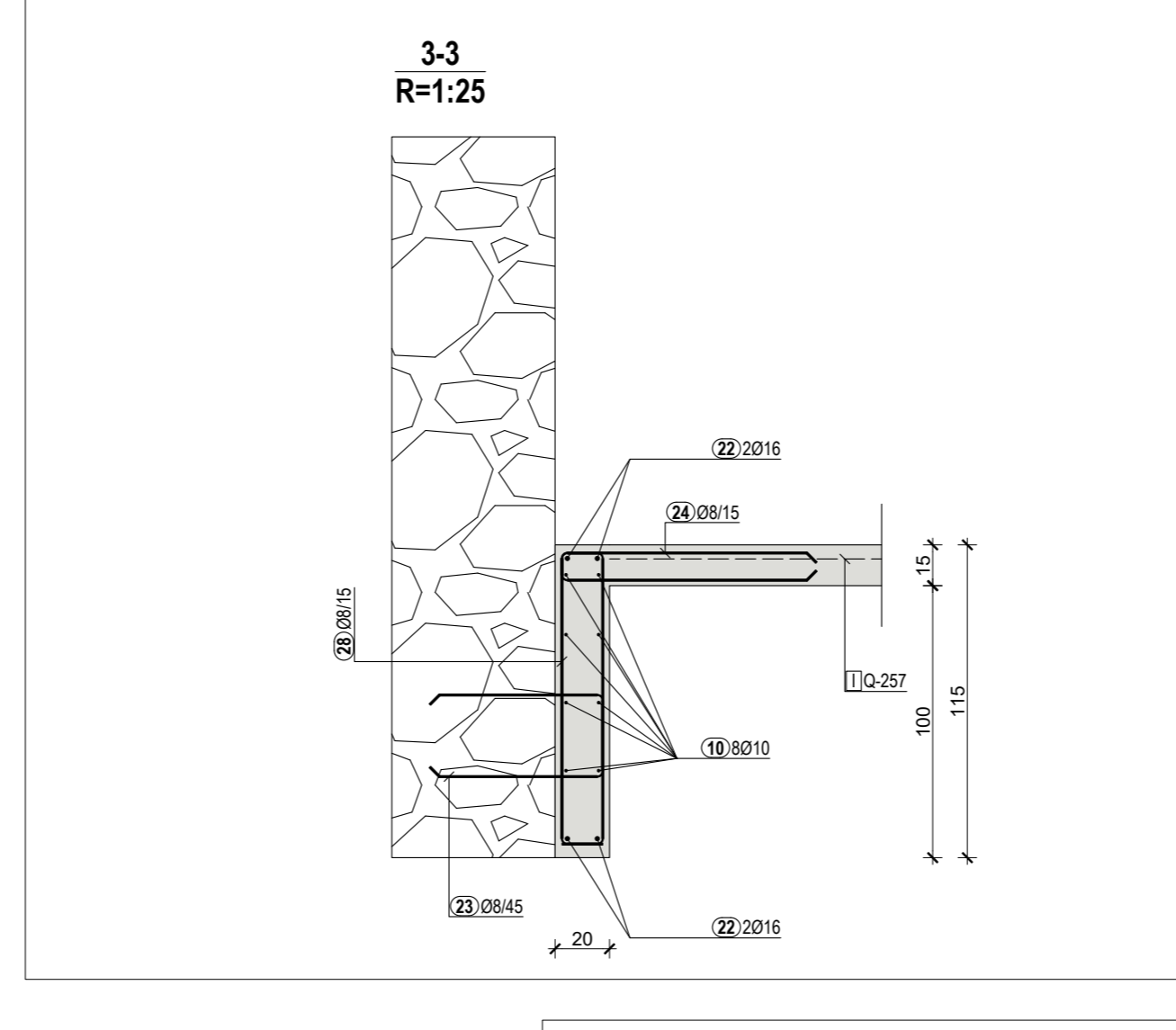
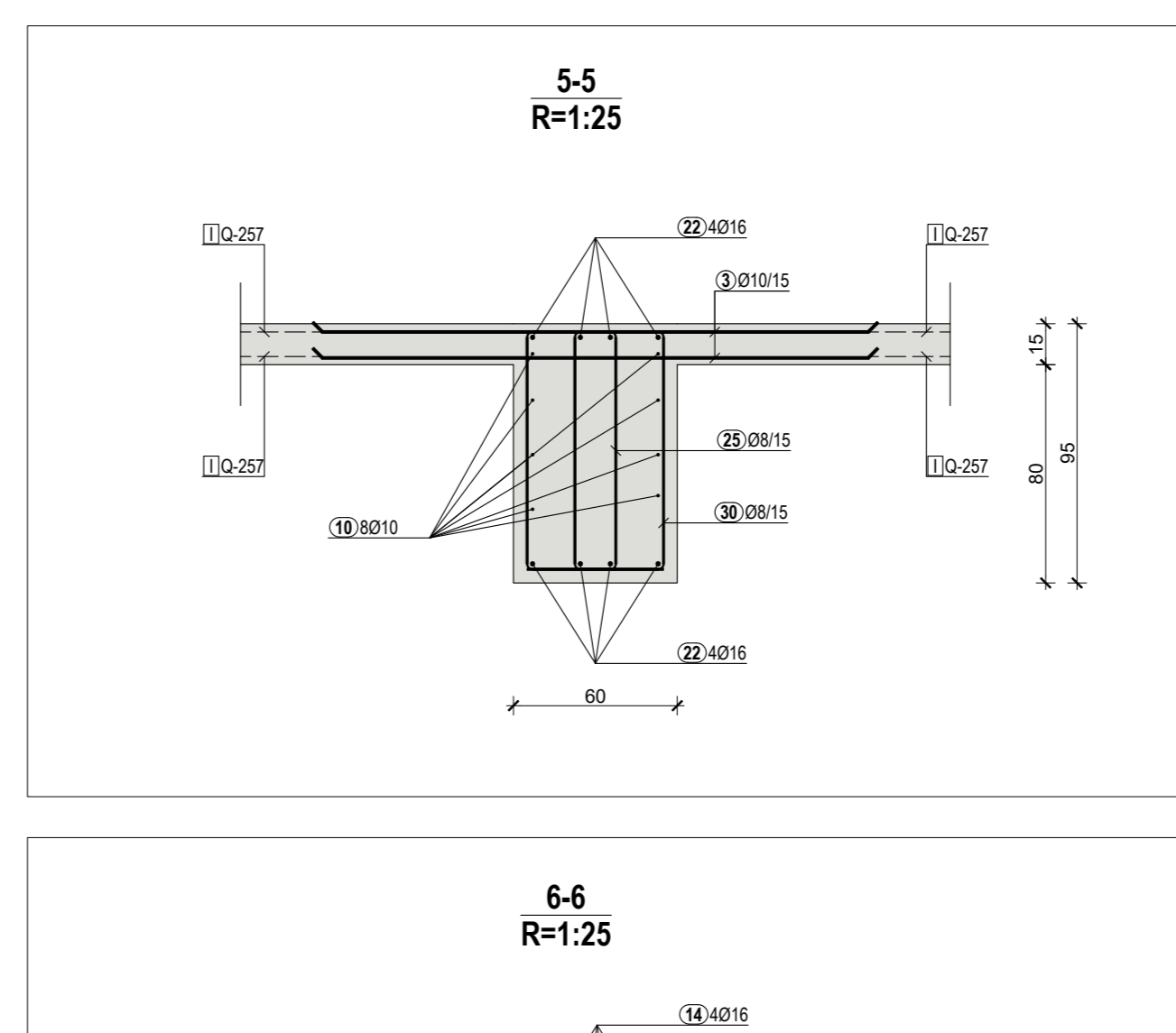
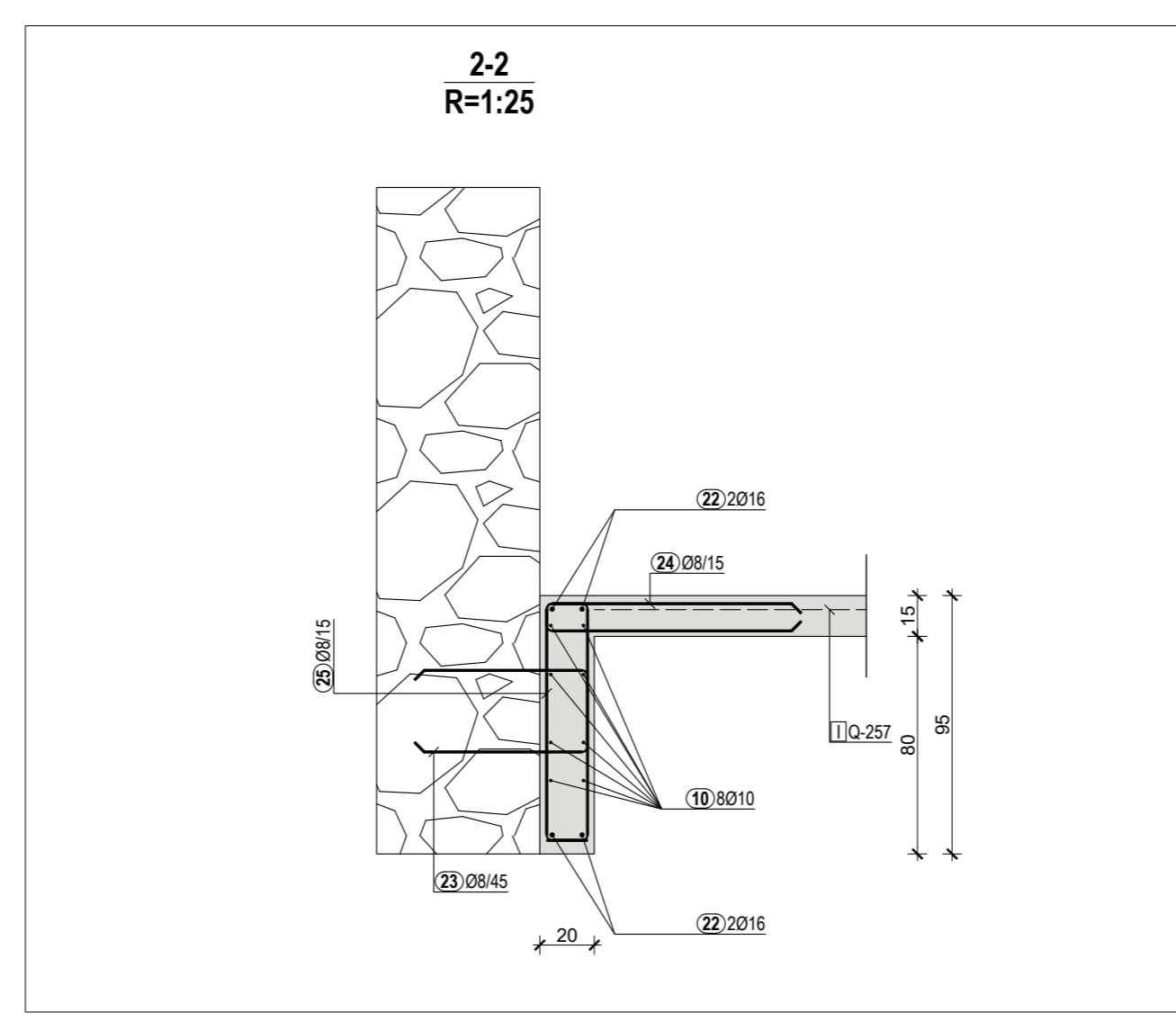
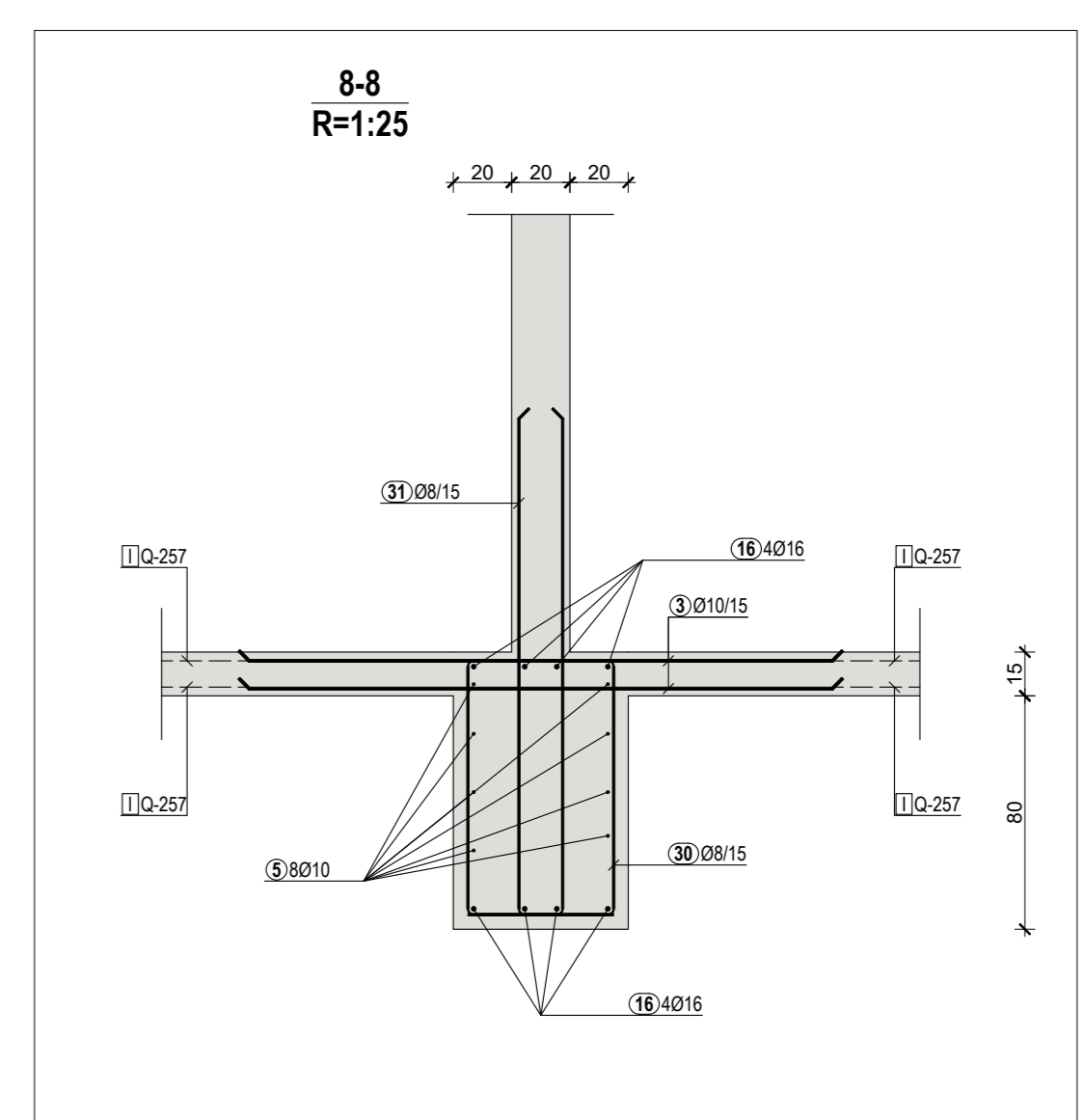
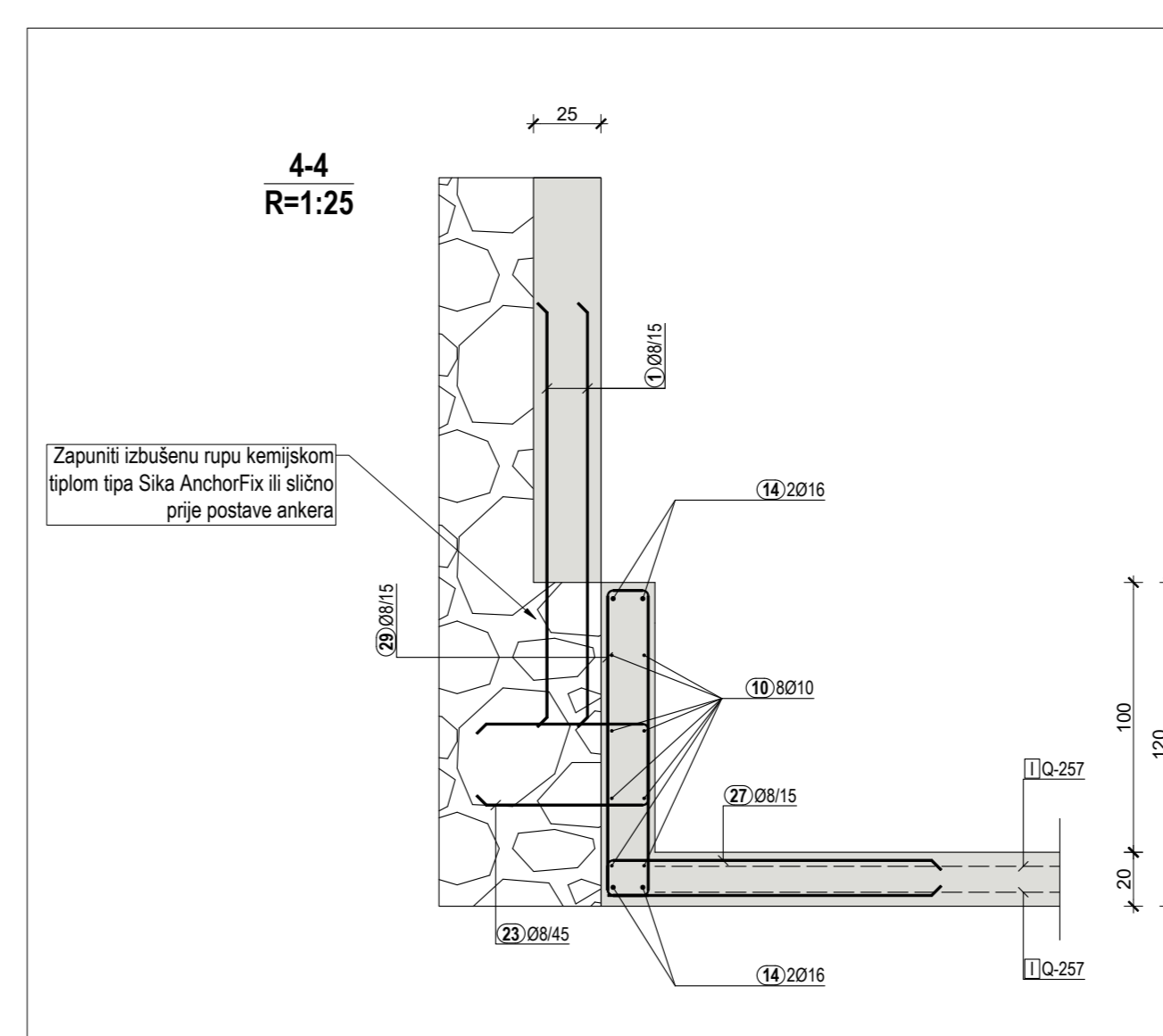
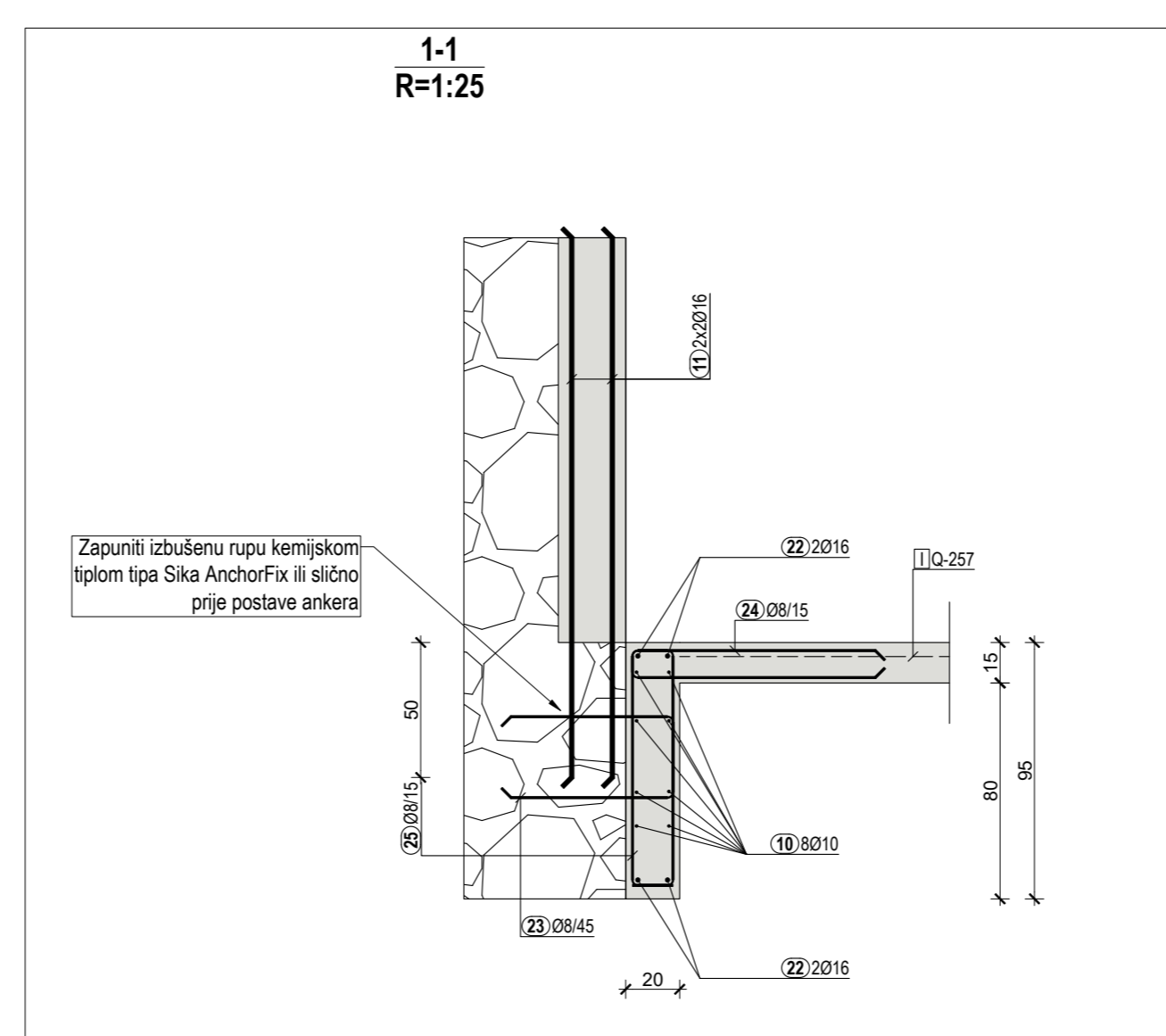
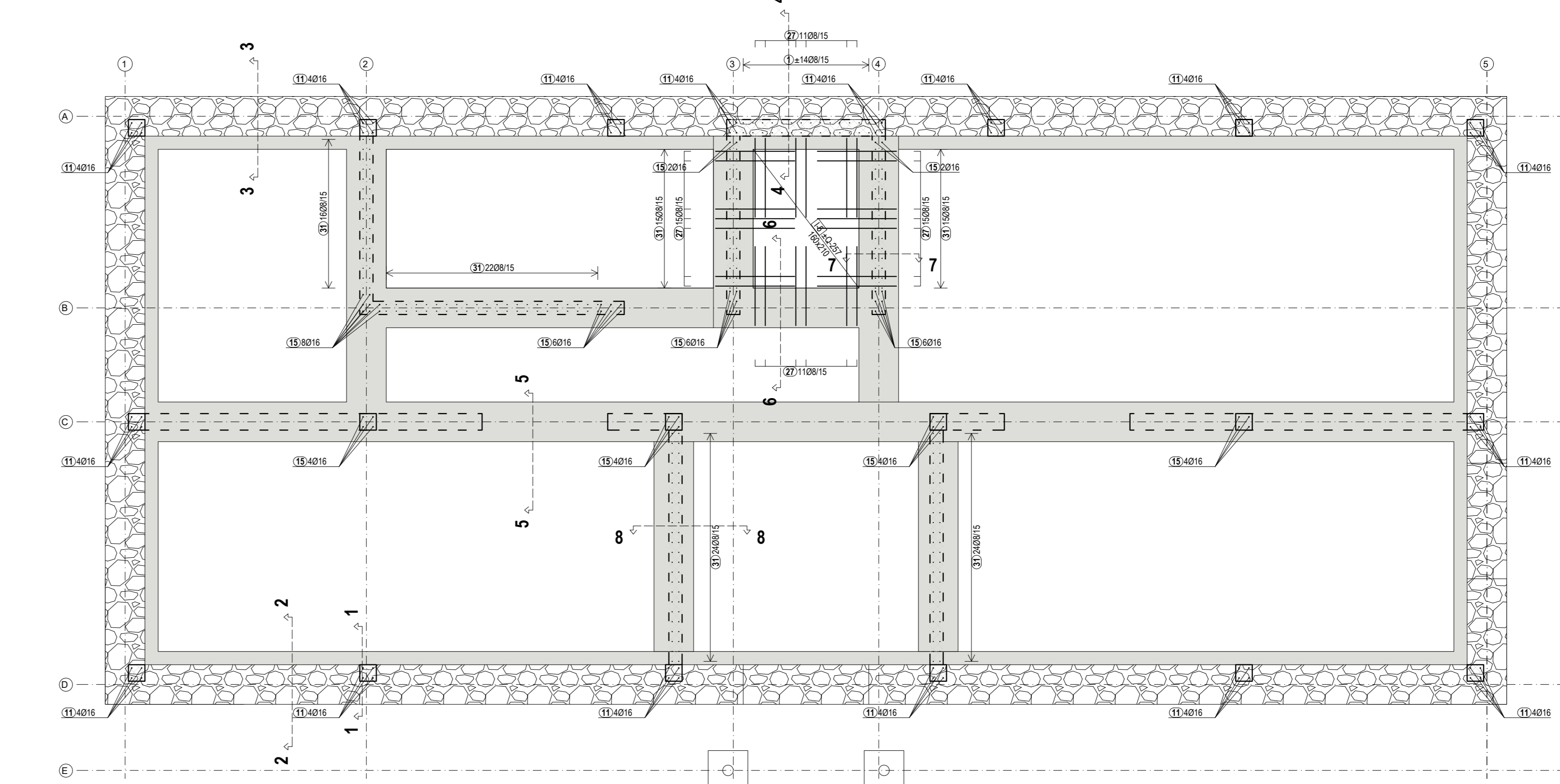

**PRINCIP ARMIRANJA ZIDA**

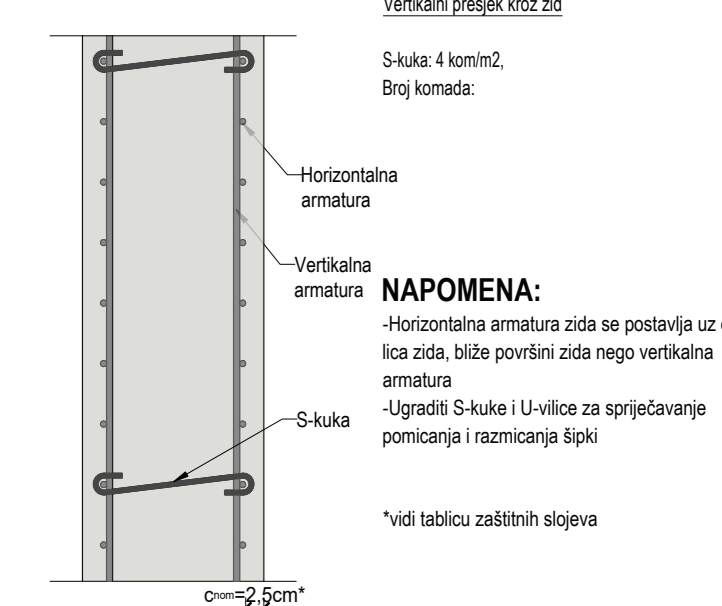

**PRINCIP ARMIRANJA PLOČE**

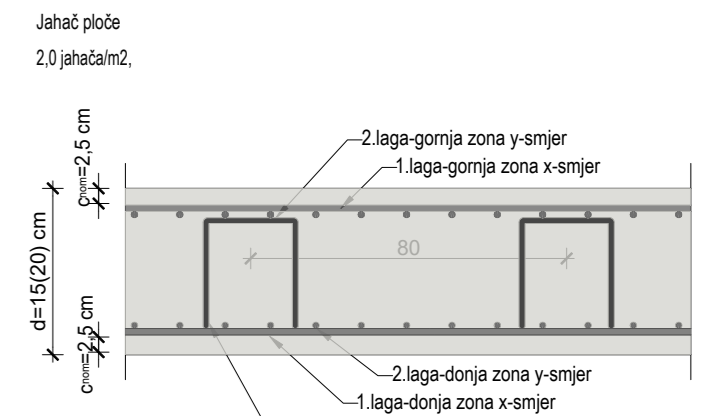

**PRINCIP PREKLAPANJA ARMATURE**

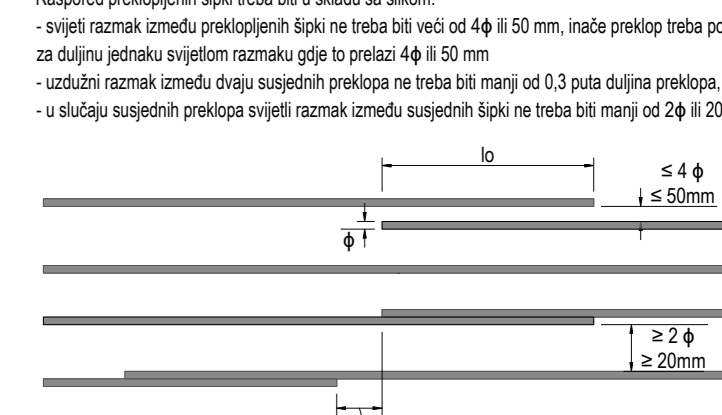

Šifra	specifikacija	kon	okup	metri	okup
1	armatura šifra #1 l = 100cm	8	1.00	28	
2	armatura šifra #1.5 l = 150cm	10	2.00	80	
3	armatura šifra #2 l = 200cm	10	2.00	488	
4	armatura šifra #2.5 l = 250cm	10	2.70	16	
5	armatura šifra #3 l = 300cm	10	4.30	16	
6	armatura šifra #3.5 l = 350cm	10	6.90	8	
7	armatura šifra #4 l = 400cm	10	7.90	16	
8	armatura šifra #4.5 l = 450cm	10	6.30	24	
9	armatura šifra #5 l = 500cm	10	13.00	24	
10	armatura šifra #5.5 l = 550cm	10	2.00	64	
11	armatura šifra #6 l = 600cm	16	2.10	8	
12	armatura šifra #6.5 l = 650cm	16	2.40	110	
13	armatura šifra #7 l = 700cm	16	2.70	28	
14	armatura šifra #7.5 l = 750cm	16	3.10	48	
15	armatura šifra #8 l = 800cm	16	3.30	16	
16	armatura šifra #8.5 l = 850cm	16	3.80	8	
17	armatura šifra #9 l = 900cm	16	6.20	8	
18	armatura šifra #9.5 l = 950cm	16	3.90	8	
19	armatura šifra #10 l = 1000cm	16	8.80	12	
20	armatura šifra #10.5 l = 1050cm	16	8.80	8	
21	armatura šifra #11 l = 1100cm	16	12.00	12	
22	armatura šifra #11.5 l = 1150cm	8	1.00	128	
23	armatura šifra #12 l = 1200cm	8	1.90	358	
24	armatura šifra #12.5 l = 1250cm	8	2.10	420	
25	armatura šifra #13 l = 1300cm	8	2.30	41	
26	armatura šifra #13.5 l = 1350cm	8	2.50	52	
27	armatura šifra #14 l = 1400cm	8	2.60	131	
28	armatura šifra #14.5 l = 1450cm	8	2.70	19	
29	armatura šifra #15 l = 1500cm	8	3.24	242	
30	armatura šifra #15.5 l = 1550cm	8	3.30	115	
31	armatura šifra #16 l = 1600cm	8	3.84	47	
32	armatura šifra #16.5 l = 1650cm	8	1.04	320	

**Legenda:**

	Armirani beton ispod	D.Z.	Donja zona armature
	Armirani beton iznad	G.Z.	Gornja zona armature
	Zidovi opseke ispod	R.	Rubna armatura
	Zidovi opseke iznad	+.	Donja armatura
		+.	Gornja podloga armature

**POVEZUJUĆA OPLOTA**

Šifra	specifikacija	kon	okup	metri	okup
1					
2					
3					
4					
5					
6					
7					
8					
9					
10					
11					
12					
13					
14					
15					
16					
17					
18					
19					
20					
21					
22					
23					
24					
25					
26					
27					
28					
29					
30					
31					
32					
33					

**U.O.I.G. Luka Kovačević** Luka 7, 1000 Zagreb  
tel: +385 (0)1 4561 1111  
e: lukak@uoiig.hr  
uoiig.hr

**GRAĐEVINA**  
REKONSTRUKCIJA ODNOSNO IZGRADNJA ZGRADE  
PODUZETNIČKOG INKUBATORA

**OPKADA:** MARČANA  
Novodolnarska čestica 796/3 k.o. Marčana (formirana od dijela  
k.č.br. 796/3, 342 zgr., 343 zgr., k.o. Marčana)

**INVESTITOR:**  
Općina Marčana  
OIB: 34665962557  
Marčane 158, Marčana

**PROJEKTANT:**  
Luka Kovačević, mag.ing.aedf.  
Inženjerska zajednica inženjera  
Luka Kovačević  
Odborbeno društvo građevinarstva  
OIB: 31195

**FAZA PROJEKTA:**  
IZVEDBENI PROJEKT

BRUILO	Z.D.P.	DATUM
XXXXX	XXXXX	svibanj 2025

**SADRŽAJ LISTA:**  
Armatura temeljnih traka i podne ploče

FORMAT	MERLO	LIST	REVIZIJA
A0	1:50	1	0

Armatura zidova prizemlja u tlocrtu  
mj 1:50, C25/30, cnom=2,5 cm

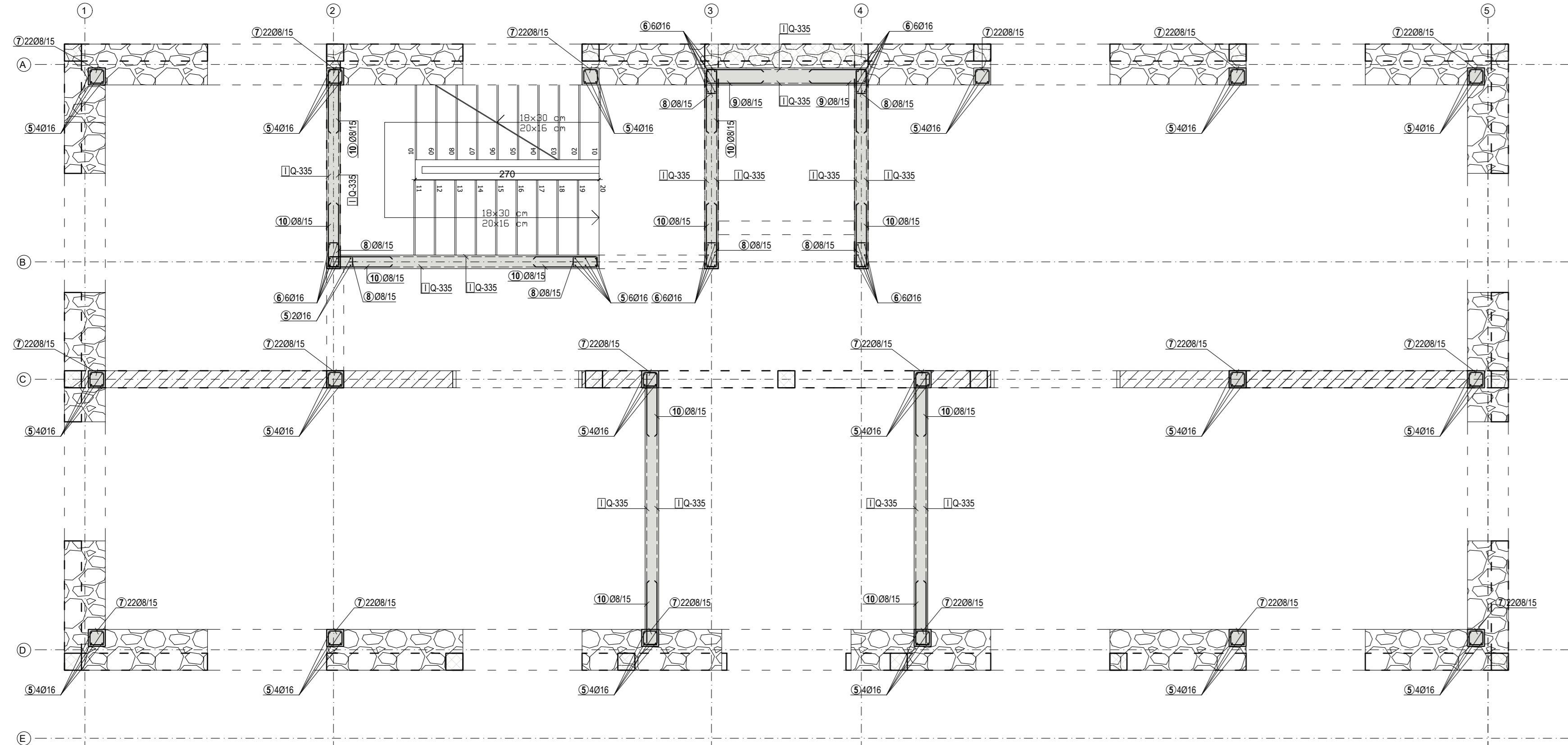

Pregledni plan zidova prizemlja  
mj 1:50, C25/30, cnom=2,5 cm

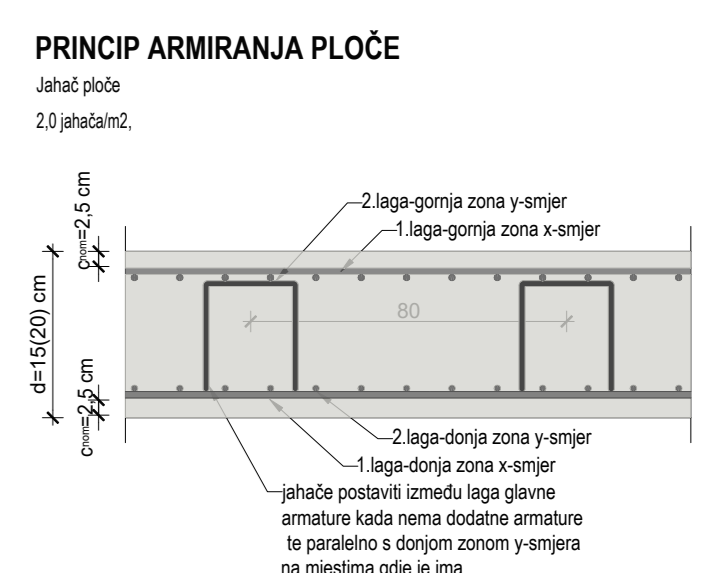
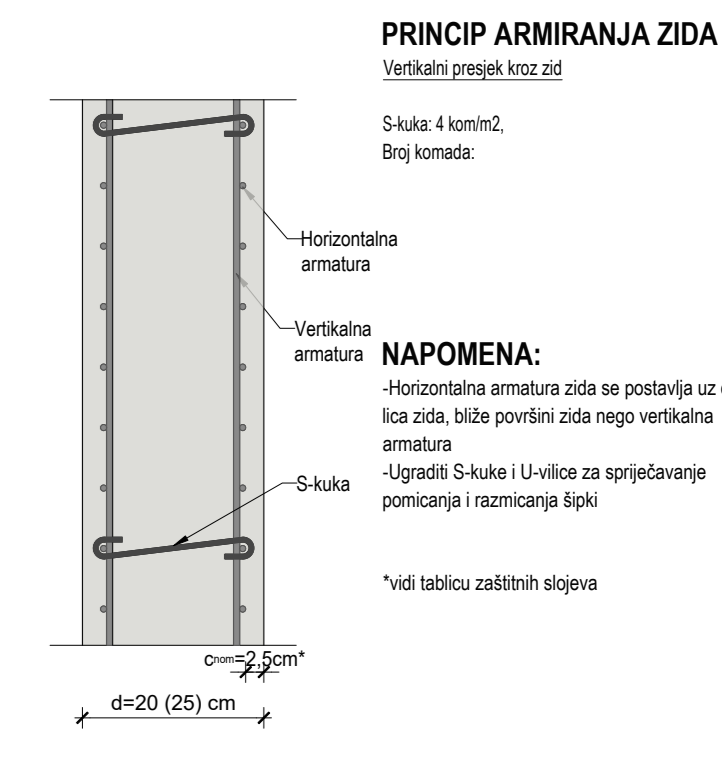
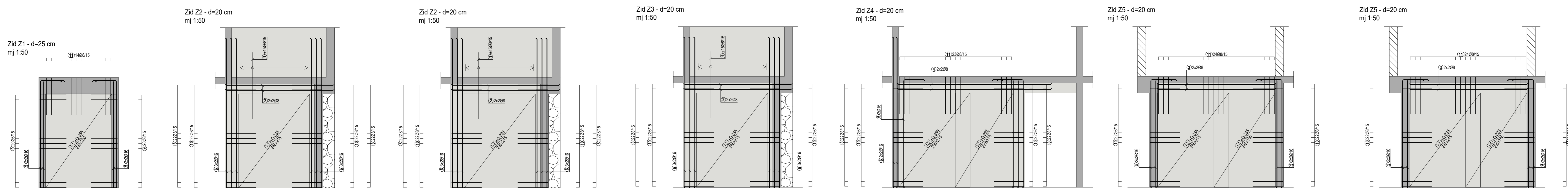
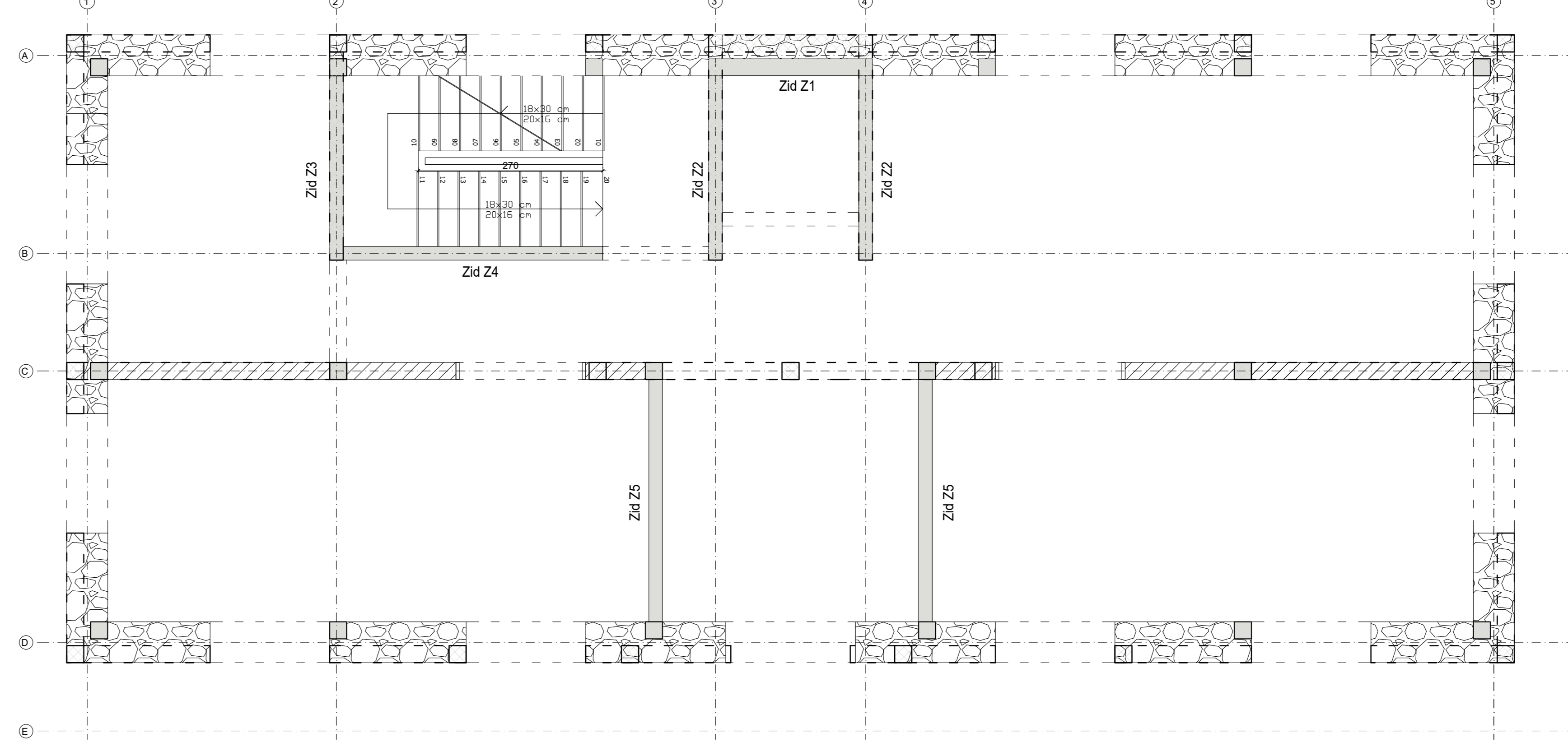

Armatura zidova 1. kata u tlocrtu  
mj 1:50, C25/30, cnom=2,5 cm

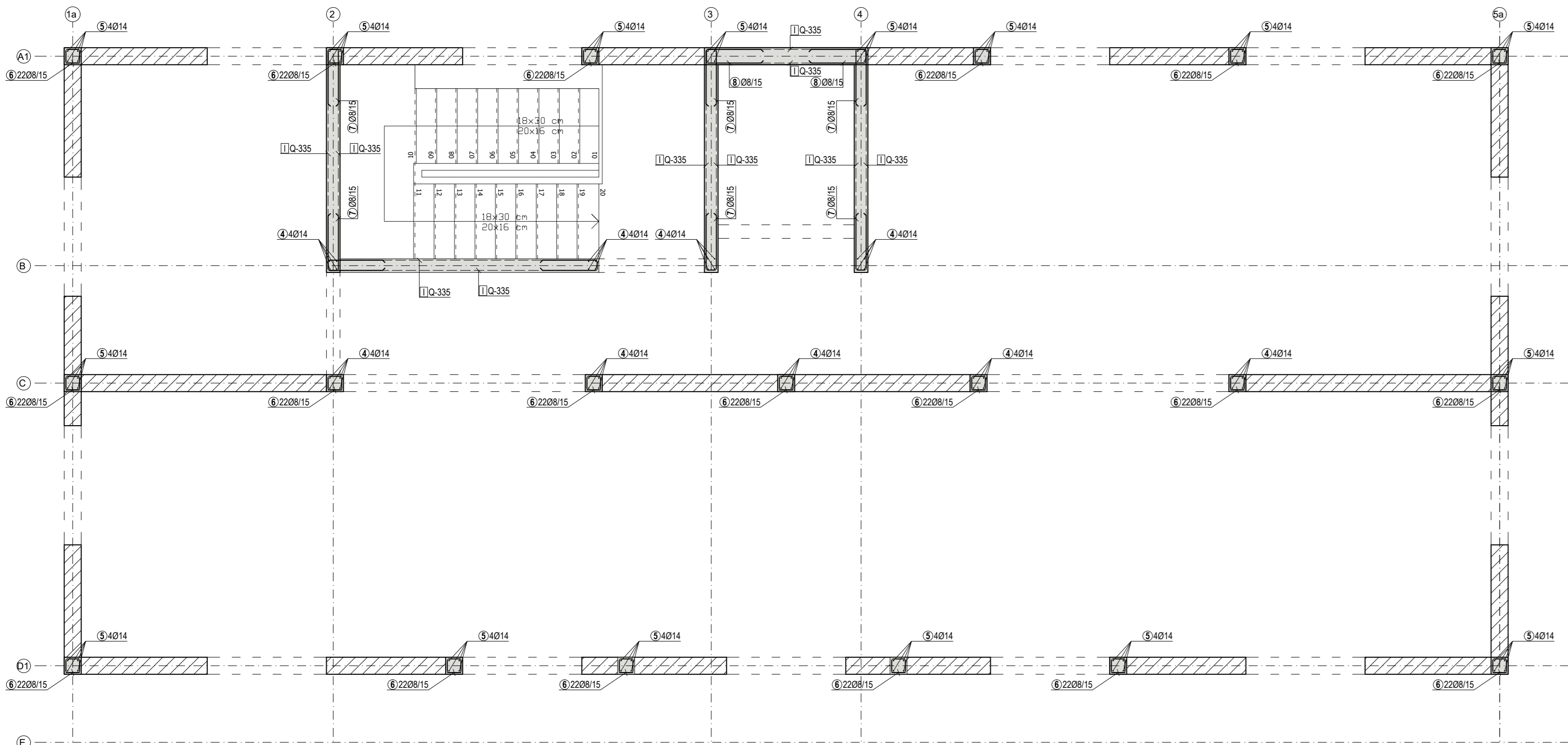

Pregledni plan zidova 1. kata  
mj 1:50, C25/30, cnom=2,5 cm

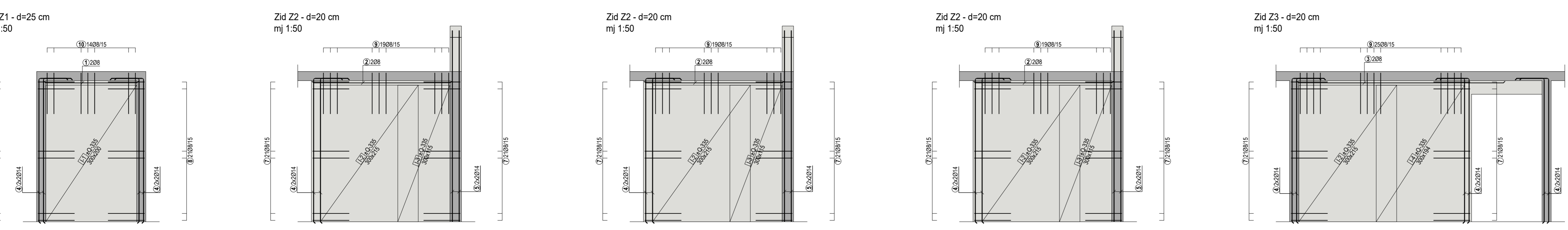
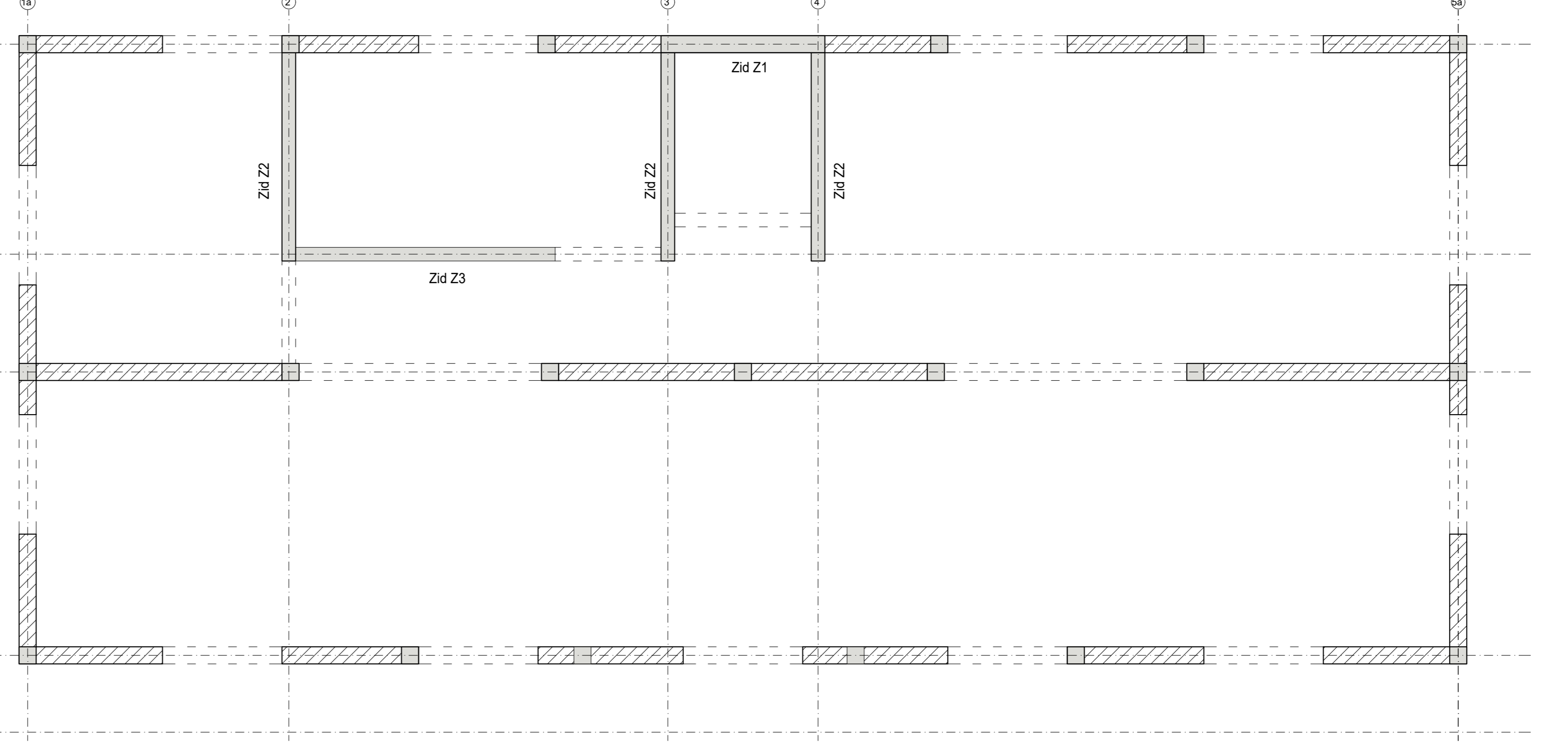

**Šipke - specifikacija**

ozn	oblik i mjere [cm]	Ø	lg [m]	n [kom]
1	rebar	8	2,00	90
2	rebar	8	3,30	12
3	rebar	8	3,30	8
4	rebar	8	4,10	4
5	rebar	16	3,80	80
6	rebar	16	4,30	30
7	rebar	8	1,50	360
8	rebar	8	1,10	154
9	rebar	8	1,80	40
10	rebar	8	1,50	264
11	rebar	8	2,30	85

**Šipke - specifikacija**

ozn	oblik i mjere [cm]	Ø	lg [m]	n [kom]
1	rebar	8	2,00	3
2	rebar	8	3,00	6
3	rebar	8	4,00	2
4	rebar	14	3,70	36
5	rebar	14	4,80	64
6	rebar	8	1,00	416
7	rebar	8	1,70	168
8	rebar	8	1,80	40
9	rebar	8	1,80	80
10	rebar	8	1,80	14

**Legenda:**

□	Armiran beton ispod	D.Z.	Donja zona armature
□	Armiran beton iznad	G.Z.	Gornja zona armature
□	Zidovi opke ispod	R.	Rubna armatura
□	Zidovi opke iznad	+	Donja armatura
□		+	Singli podloga armature

**POVEZUJUĆA OPILATA**

BR.	OPILATA	OPRE.
1		
2		
3		
4		
5		
6		
7		
8		
9		
10		

**U.O.I.G. Luka Kovačević** Izbavna 7, 1000 Zagreb  
tel: +385 (0)1 4561 1111  
e-mail: lukak@uoiig.hr  
MB: 8003002, OIB: 790529003

**GRAĐEVINA**  
REKONSTRUKCIJA ODNOSNO IZGRADNJA ZGRADE  
PODUZETNIČKOG INKUBATORA

**OPĆINA:** MARČANA  
Novodolomarska žetevica 7963 k.o. Marčana (formirana od dijela  
k.o.b.r. 7963, 342 zgr., 343 zgr., k.o. Marčana)

**INVESTITOR:**  
Općina Marčana  
OIB: 3466592557  
Marčane 150, Marčana

**PROJEKTANT:**  
Luka Kovačević, mag.ing.aedf.  
Izbavna 7, 1000 Zagreb  
tel: +385 (0)1 4561 1111  
e-mail: lukak@uoiig.hr  
MB: 8003002, OIB: 790529003

**FAZA PROJEKTA:**  
IZVEDBENI PROJEKT

**BRJETO:** Z.G.P. **DATUM:** svibanj 2025

**SADRŽAJ LISTA:**  
Armatura zidova prizemlja i kata

**FORMAT:** MjERLO: **LIST:** **REVIZIJA:**

A0	1:50	2	0
----	------	---	---



